

VALENTINE SUPER-BALL, February 7th, 2026

GOOD HEARTED GLASGOW (J8x32) 3C (4C set) Peter Knapman Guide To SCD (ex-Collins)

- 1- 8 1s turn RH & cast to 2nd place, turn partner LH 1.1/4 times
 9-16 1s dance RH across (Lady with 2s at top & Man with 3s); 1s pass RSh & dance LH across with other couple
 17-24 1s lead down the middle & back to 2nd place own side
 25-32 2s+1s+3s circle 6H round & back

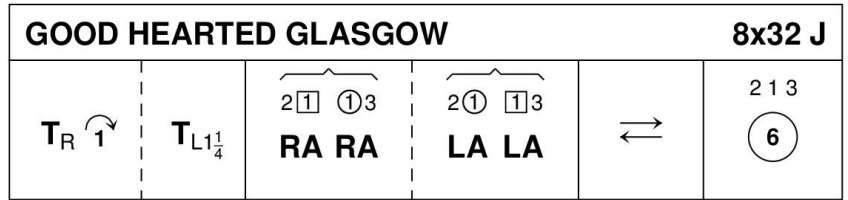

Peter Knapman, 1988, Collins Pocket Reference

3C/4C longwise set.

THE WIND THAT SHAKES THE BARLEY (R8x32) 3C (4C set) John M Duthie 8 SCDs

- 1- 8 1s lead down for 3 steps, lead back to top of set & cast into 2nd place on own sides (2s step up)
 9-16 1s dance reels of 3 across, (1M with 2s & 1L with 3s), RSh to 2nd corner
 17-24 1s turn 1st corner, partner, 2nd corner, partner
 25-32 All circle 6H round & back

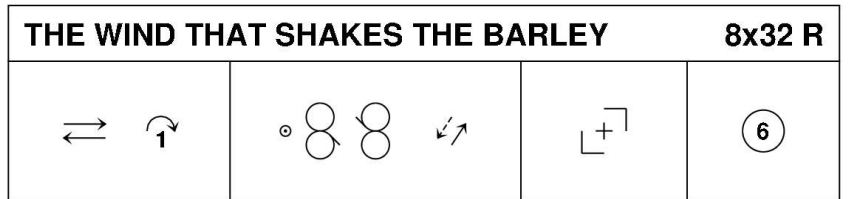

John M Duthie, 1961, Eight SCD

3C/4C longwise set.

CULLA BAY (S4x32) Sq.Set Ann Dix RSCDS Bk 41

- 1- 4 1s & 3s advance & 1/2 turn opposite partner RH & cast out to opposite side
 5- 8 1s & 3s chase 1/4 round set cl'wise & dance in passing 2s/4s RSh curving in to face 2s/4s as 2s & 4s repeat bars 1-4 & turn right about to face 1s/3s
 9-16 All dance parallel reels of 4 across set
 17-24 2s+1s **also** 4s+3s circle 4H once round to left, set & dance RH across 1/2 way
 25-32 2s+4s dance LH across once round, 2s & 4s dance out through sides passing opp partner RSh & chase round set cl'wise to next place

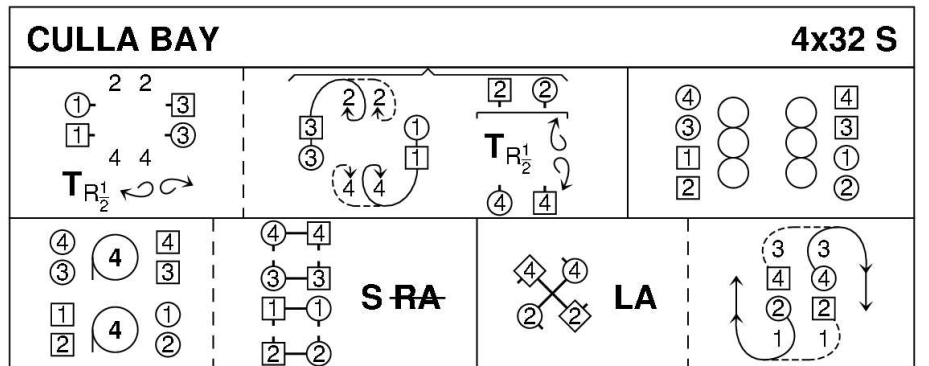

Ann Dix, 1992, Reel Friends, RSCDS Book 41.2, RSCDS Thirty Popular Dances Vol 2

4C/4C square set.

CANADIAN BARN DANCE (M16) Round the Room

Round the Room dance, couples facing anticlockwise (Ladies on partners right)

- 1- 4 Starting with outside foot run forward for three steps & hop, backwards for three steps & hop.
 5- 8 Skip sideways away from partner (men towards the centre, ladies outwards) for two steps & clap, Return to partner in waltz hold.
 9-12 Skip sideways to the man's left for two steps & back
 13-16 Polka anti-clockwise round the room.

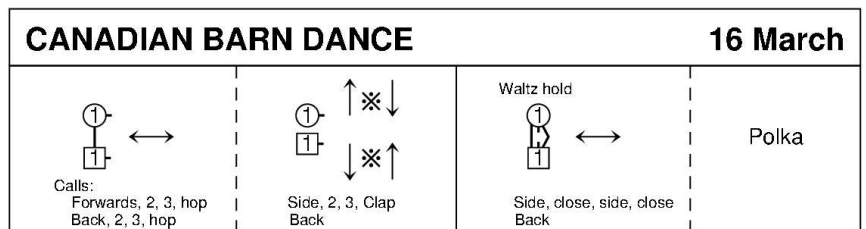

Guide to SCD

1C/1C Couple.

BIG MAC (FIVE-COUPLE MACDONALD OF THE ISLES) (S5x32) 5C Set **John Rigby Montreal Moments**

1- 8 2s & 4s dance diagonal reels of four with 1st corners & end dancing LSh round partner to face 2nd corners

9-16 2s & 4s dance diagonal reels of four with 2nd corners & ending in original places

17-24 All dance a Cumulative ("Snowball") Grand Chain:-

17-20 1s+3s cross RH & face down, 1s+2s also 3s+4s change places on the sides LH
21-24 2s cross RH as 1s+4s also 3s+5s change places RH on the sides, 2s+4s also 1s+5s change pls LH on sides as 3s cross LH. 4(2)5(1)3

25-32 4s+2s also 1s+5s dance 1/2 R&L, 4s+5s dance 1/2 Figs of 8 (Men up, Ladies down).
2 4 1 5 3

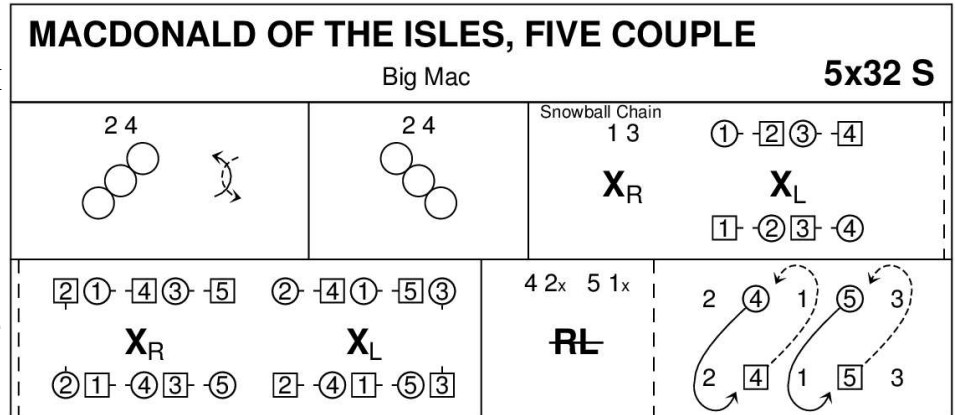

John Rigby, 1992, Nine Scottish Dances 2004, Montreal Moments

5C/5C longwise set.

STANFORD SWING (J8x40) 3C (4C set)

Bob McMurtry Devil's Quandary

1- 8 1s set & cross RH, cast 1 place & turn LH 3/4 times to face 1st corners

9-16 1s set & dance La Baratte with 1st corners:-

11-12 Men 1/2 turn facing Lady RH & retain hand but at arm's length from each other

13-14 Man retraces steps with Lady turning right under Man's arm briefly into Allemande hold (Man behind Lady facing Ladies original place) & releasing Ladies RH she turns under Mans left arm until almost in original places

15-16 Couple change places LH

17-20 1s (now in 1st corner positions) dance LSh round 2nd corners into middle **while** 1st corner persons turn RH & dance back to places

21-24 1s turn LH 1.3/4 times to face 2nd corners

25-32 1s set & dance La Baratte with 2nd corners:-

33-36 1s (now in 2nd corner positions) dance LSh round 3rd corners to 2nd place own side **while** 2nd corner persons turn RH & dance back to places

37-40 1s+4th corners dance DoSiDo

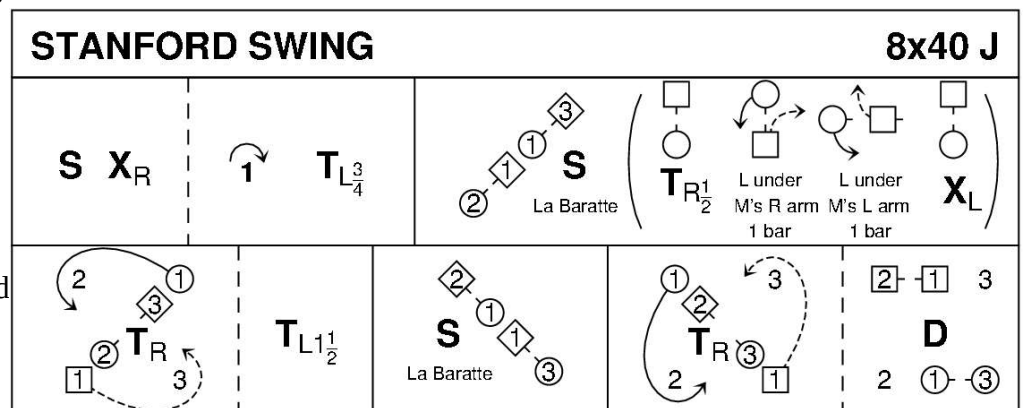

Bob McMurtry, The Devil's Quandary

3C/4C longwise set

THE HOSPITALITY CIRCLE (J32) Round the Room

Marge van Nus Lets All Dance Too

Round the Room 2 facing 2

1- 8 Ladies Adv+Ret & dance DoSiDo

9-16 Men Adv+Ret & dance DoSiDo

17-24 All dance RH across, LH back

25-32 All Adv+Ret & pass RSh to meet new couple

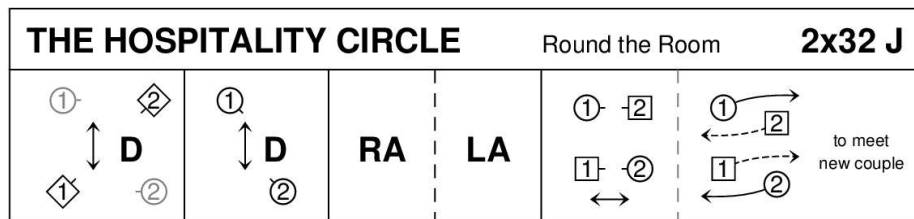

Marge van Nus, 1983, Let's All Dance Too

2C/2C Round the Room

LADY IN RED (J5x32) 5C set

Simon Scott Ruby Anniv Coll & RSCDS Bk 48

1- 4 All set, 1s+3s+5s petronella turn into centre while 2M & 4M cast up 1 place as 2L & 4L cast down 1 place

5- 8 1s+3s+5s set while 2s & 4s cross to opposite sides, 1s+3s+5s petronella turn to opposite sides while 2M & 4M cast down 1 place into middle to face up to partner as 2L & 4L cast up 1 place into middle & face down

9-16 2s+4s dance reel of 4 in middle

17-24 All dance LH across (2L+1s, 2M+3s+4L & 4M+5s) & end on opposite sides, all set & cross RH

25-32 1s+2s also 3s+4s Set+Link, 1s+4s also 3s+5s Set+Link. 2 4 1 5 3

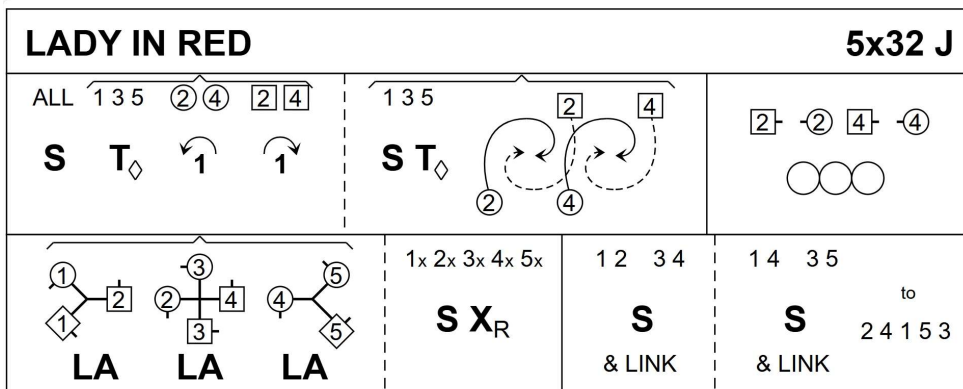

Simon Scott, Ruby Anniversary Collection 1964-2004, RSCDS Book 48.13

5C/5C longwise set.

BONNIE STRONSHIRAY (S8x32) 3C (4C set)

R Campbell Glasgow Assembly

1- 8 1s+2s 3/4 turn 2H to form line up/down centre & dance 1/2 reel of 4, 3/4 turn partners 2H to own sides (having changed places)

9-16 1s set adv to ptrn & turn 1st corner 2H ending 1L between 2s & 1M between 3s, 1s set adv to partner & turn 2nd crnr 2H ending 2nd place opp sides

17-24 2s+1s+3s cross RH & 1s cast to right round 3rd corner (pstns) while corners turn right about & Adv+Ret (on diagonal), 2s+1s+3s cross RH (up/down set), 1s cast to right round 4th corner (pstns) & in to face them as 2s+3s turn right about & Adv+Ret

25-32 1s dance 1/2 RSh reel of 4 with 4th corner (pstns), pass LSh & dance 1/2 reel with 3rd corner (pstns) & turn RH back to place

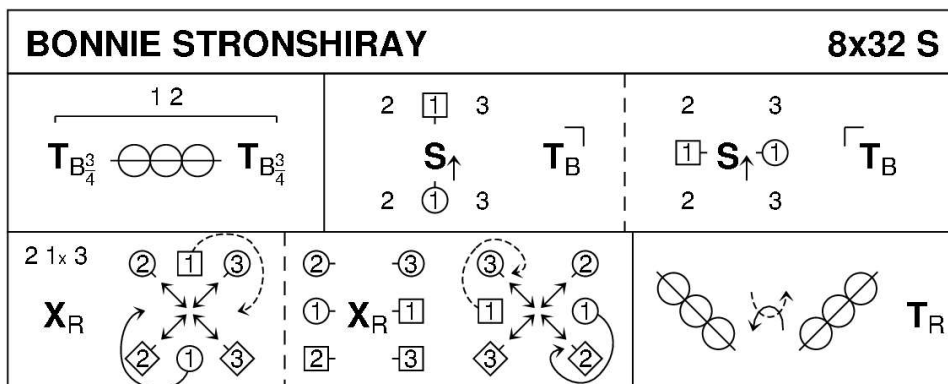

Robert M Campbell, 1963, Glasgow Assembly

3C/4C longwise set.

RED GHILLIES (R4x40) 4C set Ann Skipper & Neil McLeod If The Ghillie Fits

- 1- 8 1s cross down, cast down behind 3s, cross down & cast up around 4s to 3rd place
- 9-16 1s cross up, cast up behind 2s to 1st place & turn RH 1.1/2 times
- 17-24 1s+2s dance 1/2 R&L, 1s+3s dance 1/2 R&L
- 25-32 1s+4s dance 1/2 R&L & all turn RH
- 33-40 All set & dance a modified La Baratte :-

Men 1/2 turn partners RH & retain hand but at arm's length from each other, Men retrace steps with partner turning right under his arm briefly into Allemande hold (Men behind partner facing Men's original place) & releasing partner's RH she turns under Mans left arm & all change places LH to own sides

RED GHILLIES			4x40 R			
2x 3x 4x 1x	2x 3x 4x 1x	2x 3x 4x 1x				
T_R	S	La Baratte	T_R 1/2	X_L		

Ann Skipper & Neil Stewart McLeod, If The Ghillie Fits

4C/4C longwise set.

A HOLLYWOOD PRODUCTION (S3x32) 3C Set

M. Landon 2019

- 1- 4 2nd and 3rd couples dance mirror set and link with 2nd couple dancing down the centre, touching nearer hands, as 3rd couple cast up. 1st couple stand.
- 5- 8 1st and 3rd couples dance mirror set and link with 1st couple dancing down, touching nearer hands, to end facing out in 2nd place as 3rd couple cast up. The order is now 3,1,2.
- 9-12 1st couple cast to their right around 3rd corners and come in to face each other on the 2nd corner diagonal, briefly taking both hands. Meanwhile 3rd and 2nd couples advance diagonally, briefly taking hands in a circle (1st corners offering their hands palm up) and retire to place.
- 13-16 1st couple pull right shoulder back and cast to their right around 2nd corners to end in 2nd place facing in. Meanwhile 3rd and 2nd couples again advance and retire as in bars 9-12.
- 17-24 All dance "push-me pull-you" reels on the sides. 1st couple follow the track of a left shoulder reel of three while 3rd and 2nd couples dance back to back twice, first passing left shoulder on bar 17, then right shoulder on bar 21. 1st couple end on the centre line, right shoulder to each other, 1st man below 1st woman.
- 25-28 1st woman with 3rd couple at the top and 1st man with 2nd couple at the bottom dance left hands across. At the end 1st couple pass left shoulder to face each other up and down on the centre line, 1st man above 1st woman.

- 29-32 1st couple set to each other then turn three quarters with both hands to end on the sidelines in the order 3,1,2. (Dance crib compiled by the deviser, Murrough Landon, CC BY-SA January 2019

A HOLLYWOOD PRODUCTION			3x32 S	

Murrough Landon, 2019, <http://my.strathspey.org/u/murrough/HollywoodProduction.pdf>

3C/3C longwise set.

AN INCURSION OF WEASELS (J8x32) 3C (4C set)

M Landon 2020

- 1-8 1s cast (2s step up), 1s turn RH remain in centre facing own side; 1s dance 1/2 Fig 8 (1M down round 3M, 1L up round 2L) & face 1st corners
- 9-16 1s+1st corners dance diagonal RSh Weasel Reel:
All dance part reel of 4 on 1st corner diagonal but when reaching either end they chase clockwise to other end to re-enter reel.
Corners end in original places, 1s end in centre facing opp sides, 1M below 1L
- 17-24 1L+2s & 1M+3s dance RH across; 1s pass RSh to dance LH across with other couple. 1s end facing 2nd corner
- 25-32 1s+2nd corners dance diagonal LSh Weasel Reel:

Reel as bars 9-16 on 2nd corner diagonal, but bar 32: 1s do not pass RSh but curve left to face out in 2nd place own side. 2 1 3
Note: After 2nd turn 1s cast to 4th place as 4s step up bars 1-2 of next repeat

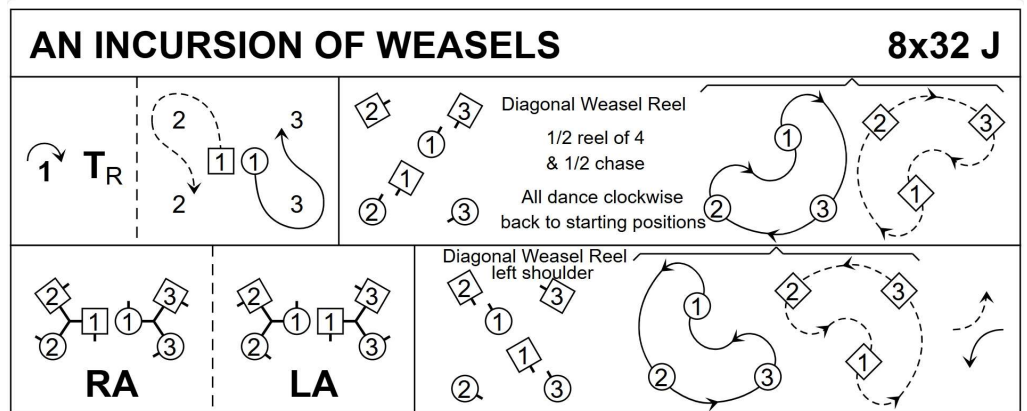

Murrough Landon, 2020, <https://my.strathspey.org/u/murrough/IncursionOfWeasels.pdf>

3C/4C longwise set.

THE GALLOPING CAROUSEL (J4x32) 4C set

John de Chastelain Ottawa 25 Dances

- 1-8 1s+2s **also** 3s+4s dance RH across, 1L **also** 4M followed by partner chase round clockwise to other end of dance
- 9-16 4s+2s **also** 3s+1s dance RH across, 1L **also** 4M followed by partner chase round clockwise back to places
- 17-24 1s+2s **also** 3s+4s set facing on sides & change places RH, middle couples set facing on sides & change places LH
- 25-32 Middle couples lead up/down between end couples, cast back to place & all turn RH. 2 4 1 3

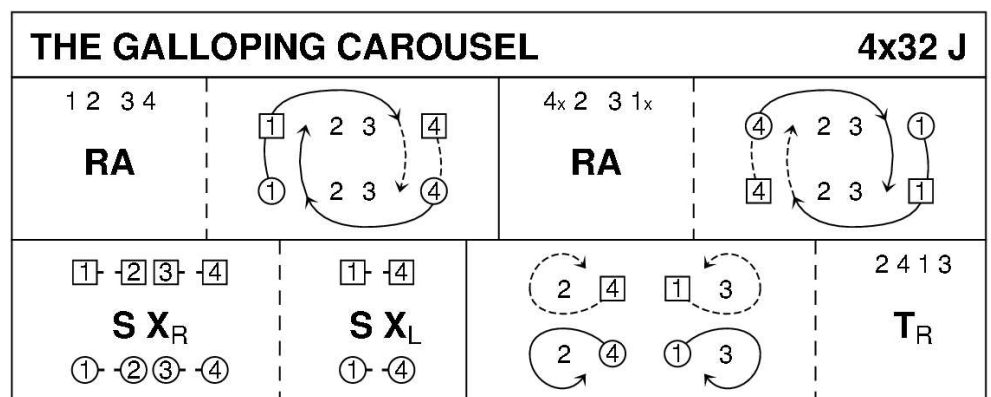

John de Chastelain, RSCDS Book 53, 25 Dances for 25 Years

4C/4C longwise set.

SWISS LASSIE (R8x32) 3C (4C set) Rosi Betsche RSCDS Bk 39

- 1- 8 1s dance in & cast to 3rd place, 2s+1s turn partners RH 1.1/4 times to form a line up & down middle of set (Men facing down Ladies up)
- 9-16 2s+1s dance reel of 4 up & down middle of set ending with 2M facing Ladies side & 1L facing Men's side
- 17-24 2s+1s chase round clockwise 1/2 way, 1s+3s+2s Adv+Ret
- 25-32 3s+2s (bottom 2 couples) 1/2 turn partners RH, dance RH across 1/2 way, 1s+2s (top 2 couples) 1/2 turn partners RH & dance RH across 1/2 way

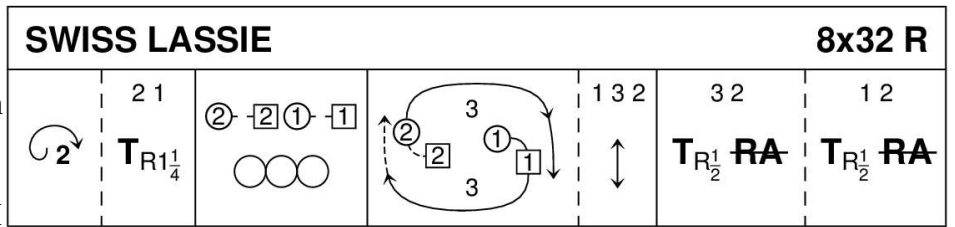

Rosi Betsche, RSCDS Book 39.1

3C/4C longwise set.

THE GLASGOW HIGHLANDERS (S8x32) 2C (4C set) RSCDS Bk 2

- 2 Ch - 1M stand as 1L crosses to 2M pl who crosses to ptrns pl, 2L steps up
- 1- 8 1s+2s dance R&L ending with 2M between 1L+2L facing down 1M directly behind 2M
- 9-16 All dance down middle, turn right about & 1M dances Ladies back to top (2M follows) to form a line 4 across with Men BtoB facing partners
- 17-24 All set to partners with suitable step
- 25-32 All dance reel of 4 across ending in new pstns with each couple having moved 1 place anticlockwise round set. On bars 31/32 3M crosses to partners place as 3L steps up to start next 32 bars

Similarly on bars 31/32 (2nd time through) 4M crosses to partners places as 4L steps up

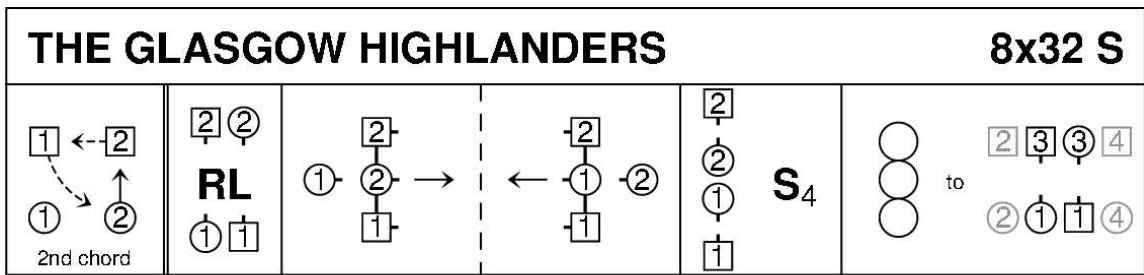

Walter F Gillies, c.1885, RSCDS Book 2.3

2C/4C longwise set.

THE BRITANNIA TWOSTEP (M16) Round the Room

- Round the Room in 3s facing anticlockwise
- 1- 4 Nearer hands joined, touch the left heel then the left toe to the floor, bouncing on the right foot with each touch, All skip to the left for one step. Repeat with opposite feet.
- 5- 8 Skip forward for two steps, then backwards for two steps.
- 9-12 All set & Ladies turn under Mans arms
- 13-16 Skip forward for two steps, then backwards for two steps

ANDY ROSS STRATHSPEY (S8x32) 3C (4C set)

A. Taylor 2025

- 1- 8 1s+2s dance 3/4 R & L. 1C turn 1/2 RH and twirl to end facing 1st corner
- 9-24 Set and Cast Away
 - 9-12 1s set to 1st corners and dance RSh round each other into 3rd corner position while 1st corners dance in and turn right about to face their original position
 - 13-16 1s and 1st corner person set, 1st corners dance RSh round each other into diagonally opposite corners while 1s dance in and pivot to right to face 2nd corner positions
 - 17-24 1s repeat bars 9-16 with 2nd corners and pass RSh to finish 2nd place on opposite sides
- 25-32 All set and link for 3 twice

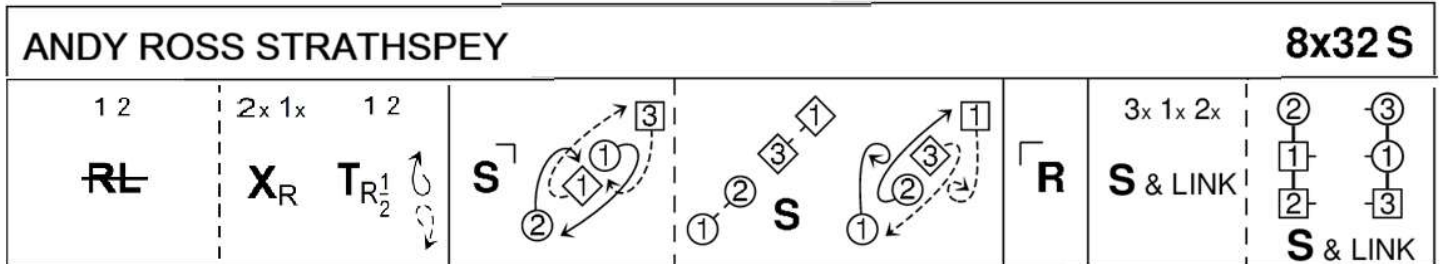

Sandy Taylor 2025

3C/4C longwise set.

THE REEL OF THE ROYAL SCOTS (R8x32) 3C (4C set) Roy Goldring RSCDS Leaflet Dances 27

- 1- 8 1s 1/2 turn 2s on sides (1M RH - 1L LH) to face out, 2s+1s+3s set, 1s 1/2 turn 3s on sides (1M LH - 1L RH) end 3s facing out & 2s+3s+1s set
- 9-16 1s followed by 3s dance up between 2s, cast down 1 place, dance in & 1s cast up to 2nd place 3s end in 3rd place
- 17-24 1s turn 1st corners RH, pass partner RSh turn 2nd corners RH & cross passing partner RSh to 2nd place own sides
- 25-32 2s+1s+3s circle 6H round & back

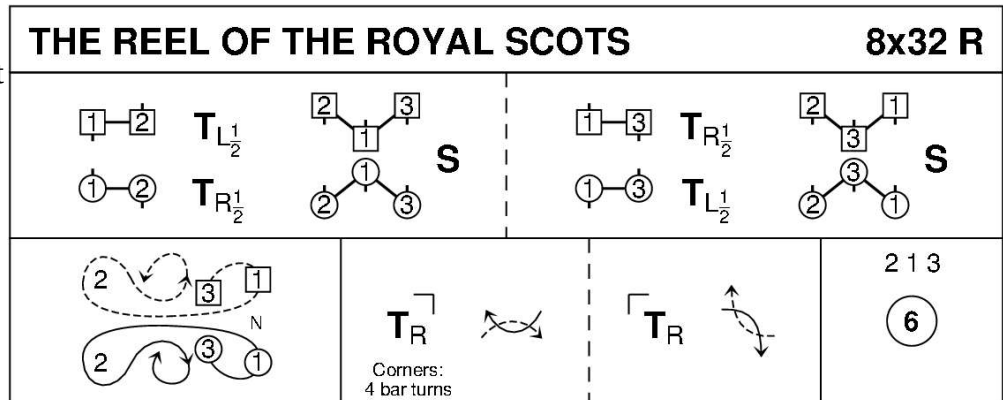

Roy Goldring, 1983, RSCDS Leaflet 7

3C/4C longwise set.